

RIGHT SIDE PANEL

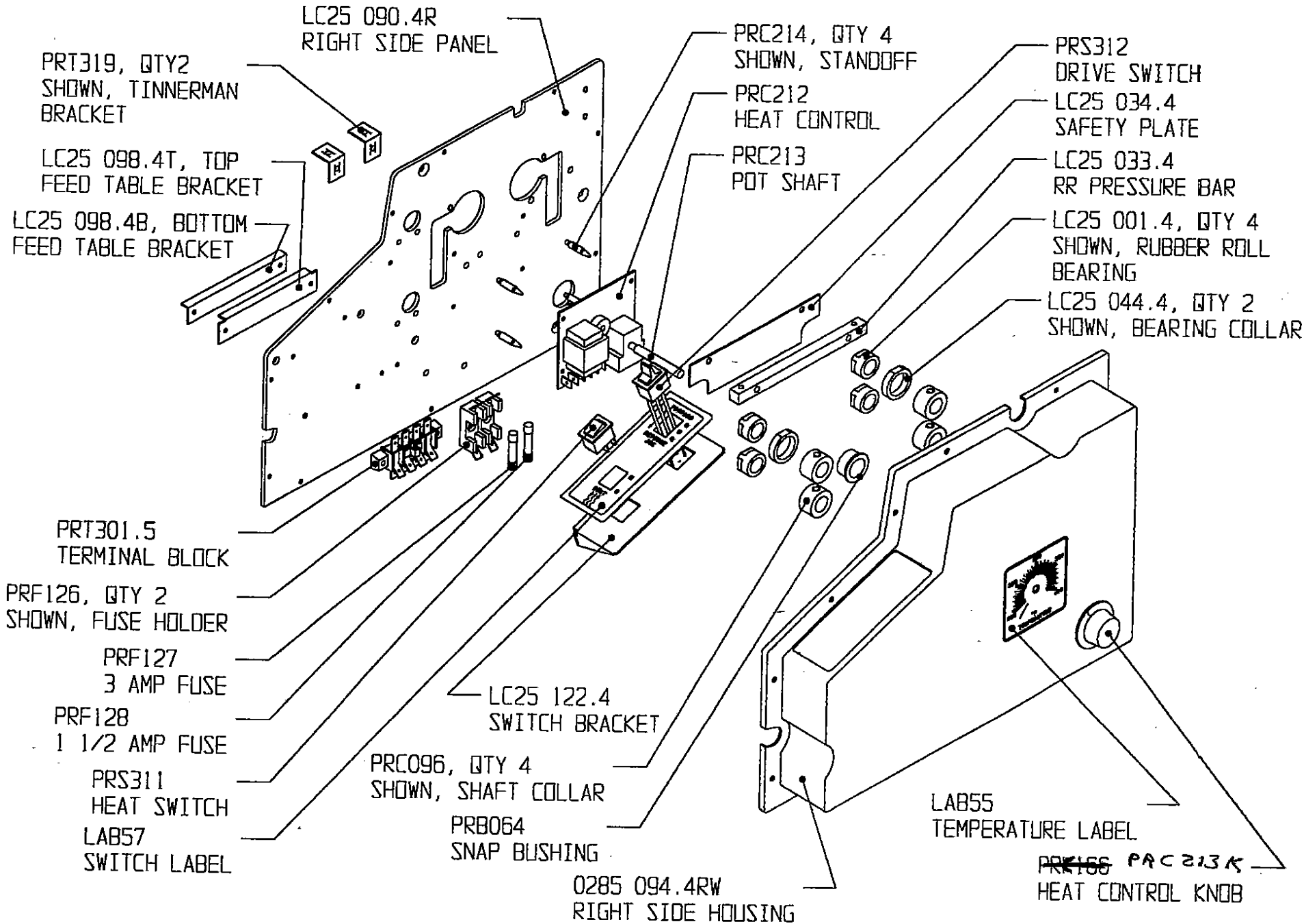

P.1
NO. 515

LED CO. INC

5:53PM

NOV. 6. 2007

LEFT SIDE PANEL

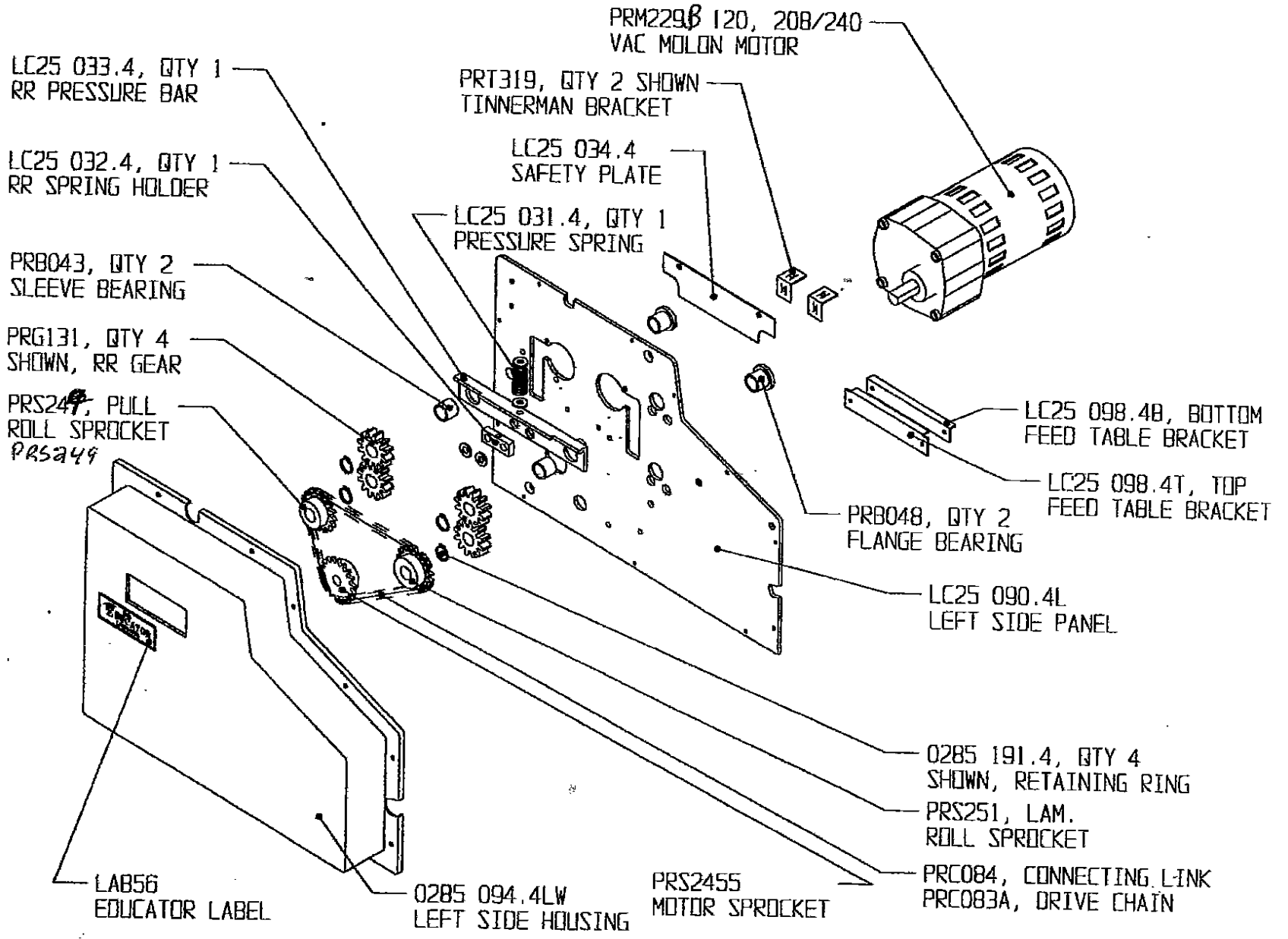

MOTOR COVER & HEAT SHOES

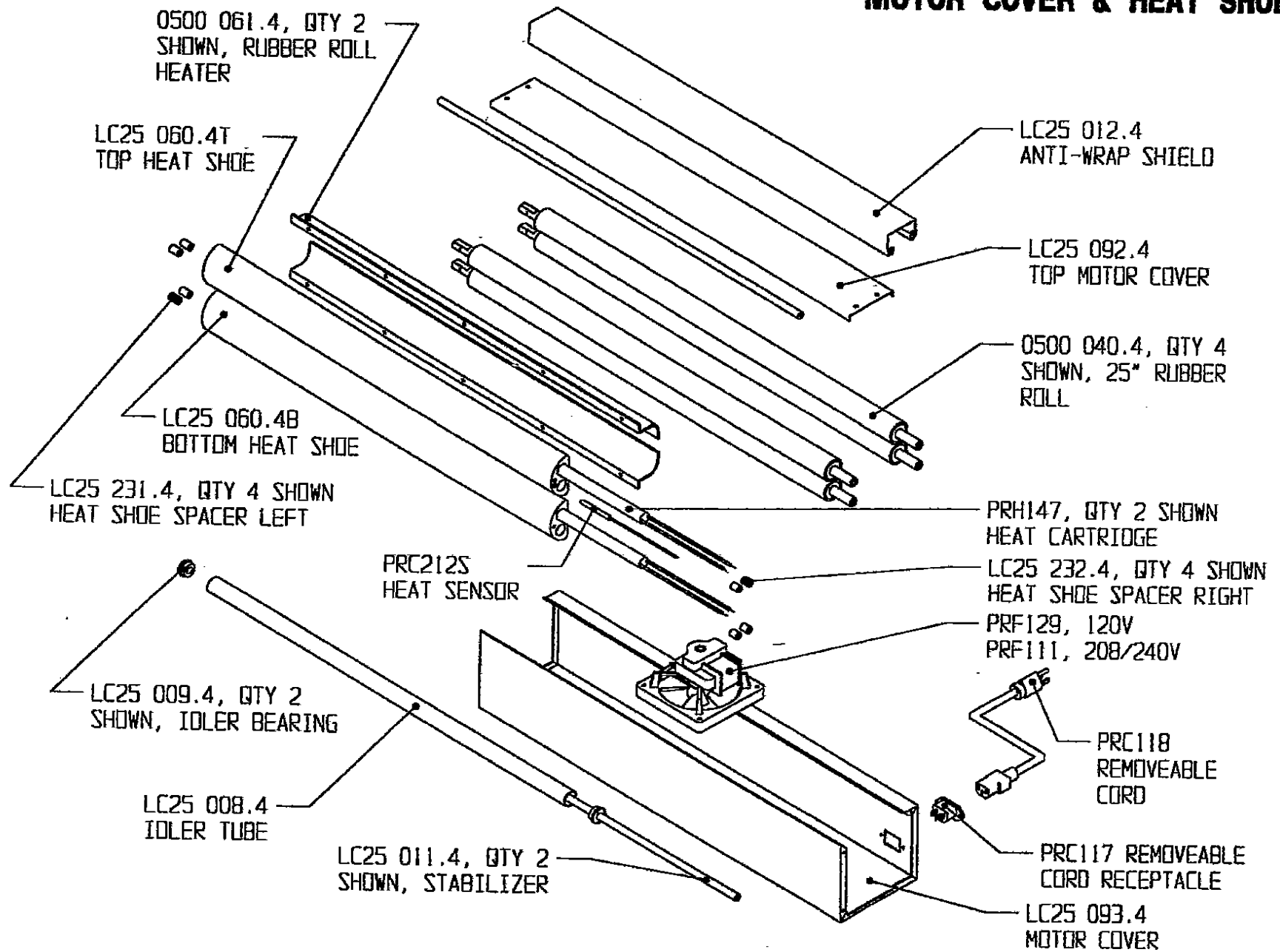

FEED TABLE, SAFETY SHIELD & SUPPLY ROLL

NOTE: COMPLETE SUPPLY ROLL ASSEMBLIES AVAILABLE
0500 002.5T, TOP SUPPLY ROLL
0500 002.5B, BOTTOM SUPPLY ROLL

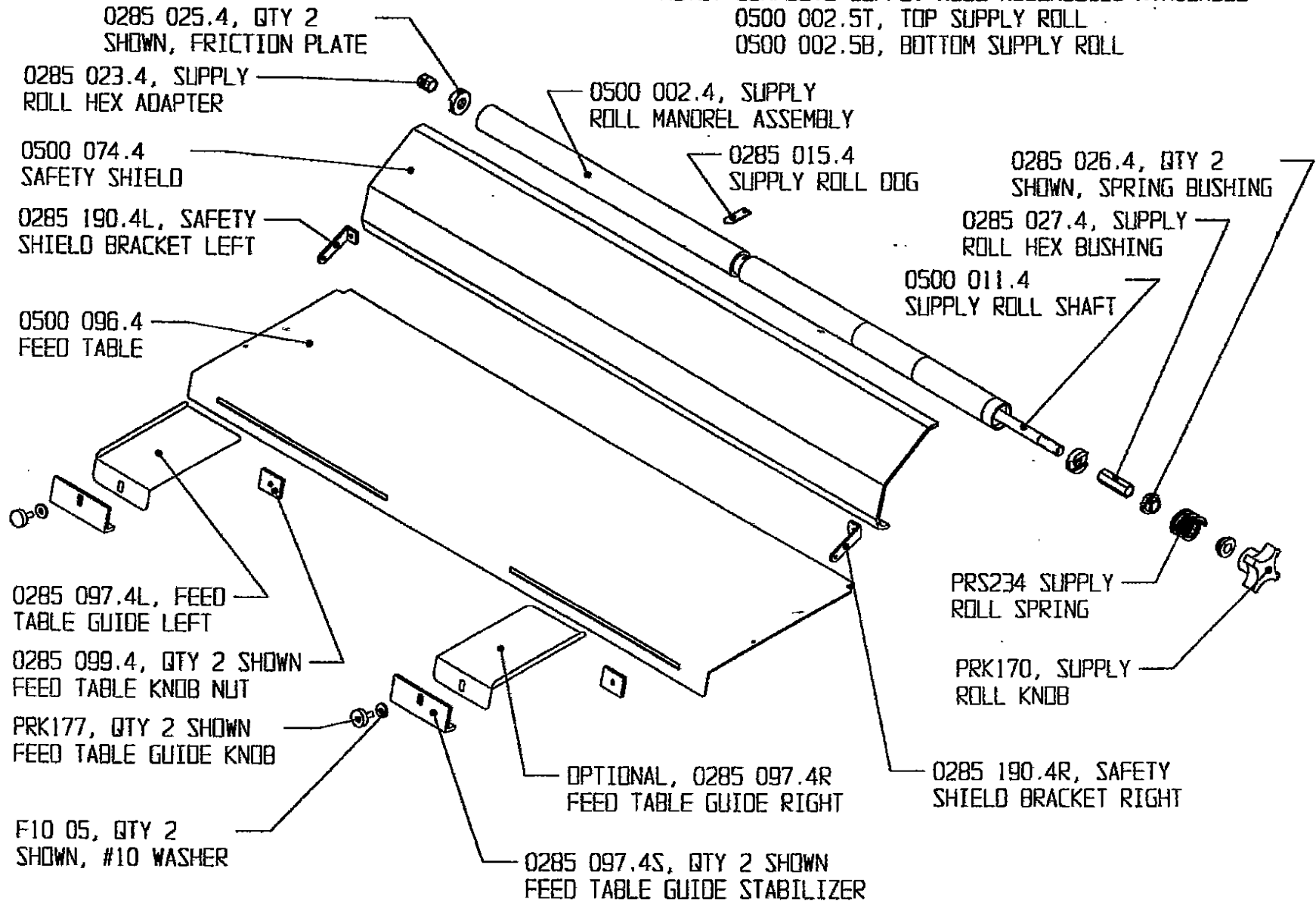

PRESSURE PLATE SUB ASSEMBLY

Replaces portions of drawing on page 29.

*These parts
need to move
smoothly yet freely*

